

The gLite Information System

Giuseppe La Rocca
Diego Scardaci

INFN – Catania

BIONFOGRID Initial training course
BARI, 08-10 March 2006



HOW TO DISCOVER resources ?

- Once an user is logged into an User Interface (s)he is ready to take advantage of the Grid Power for his/her own application.
- But what are the available resources to accomplish his/her tasks?
- The answer to this question comes through the interactions with the **Information System (IS)**.
- The Information System (IS) provides information about the LCG-2 Grid resources and their status.

HOW TO discover resources (cont)

- The data published in the IS conforms to the **GLUE (Grid Laboratory for a Uniform Environment) Schema**. The **GLUE Schema** aims to define a common conceptual data model to be used for Grid resources
- In LCG-2, the *BDII (Berkeley DB Information Index)*, based on an updated version of the **Monitoring and Discovery Service (MDS)**, was adopted as main provider of the Information Service
- In gLite, *R-GMA (Relational Grid Monitoring Architecture)* is adopted as IS

Monitoring and Discovery Service

- Computing and storage resources at a site implement an entity called **Information Provider**, which generates the relevant information of the resource (e.g.: the used space in a SE).
- This information is published by the **Grid Resource Information Servers**, or GRISes.

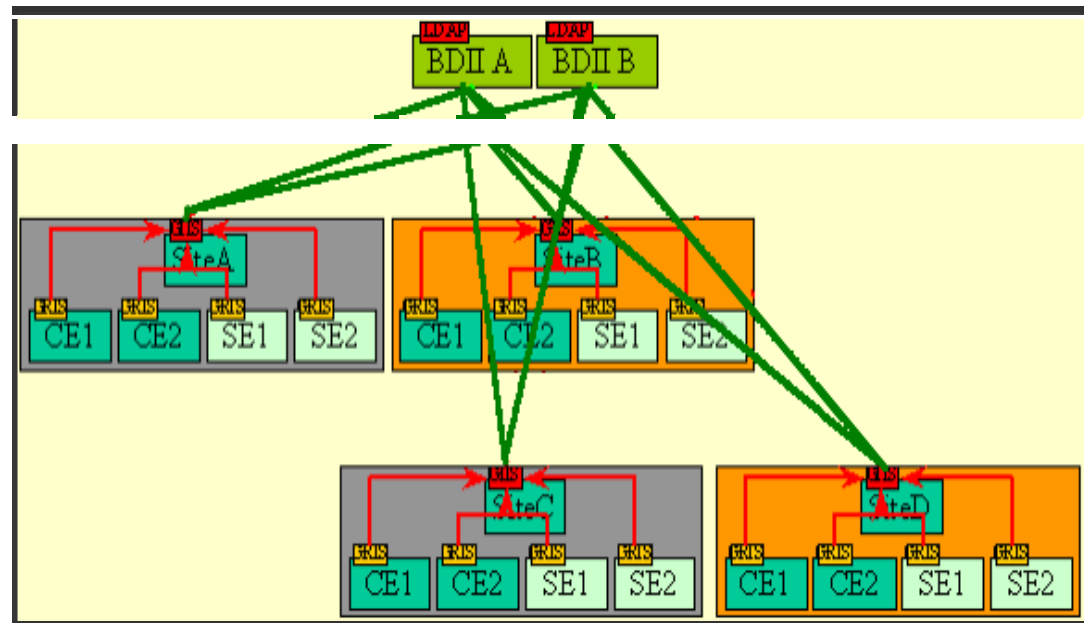

Monitoring and Discovery Service

- In each site an element called the **Site Grid Index Information Server (GIIS)** collects all the information of the different GRISes and publishes it.
- This **BDII** queries the **GIISes** and acts as a cache, storing information about the **Grid status** in its database.

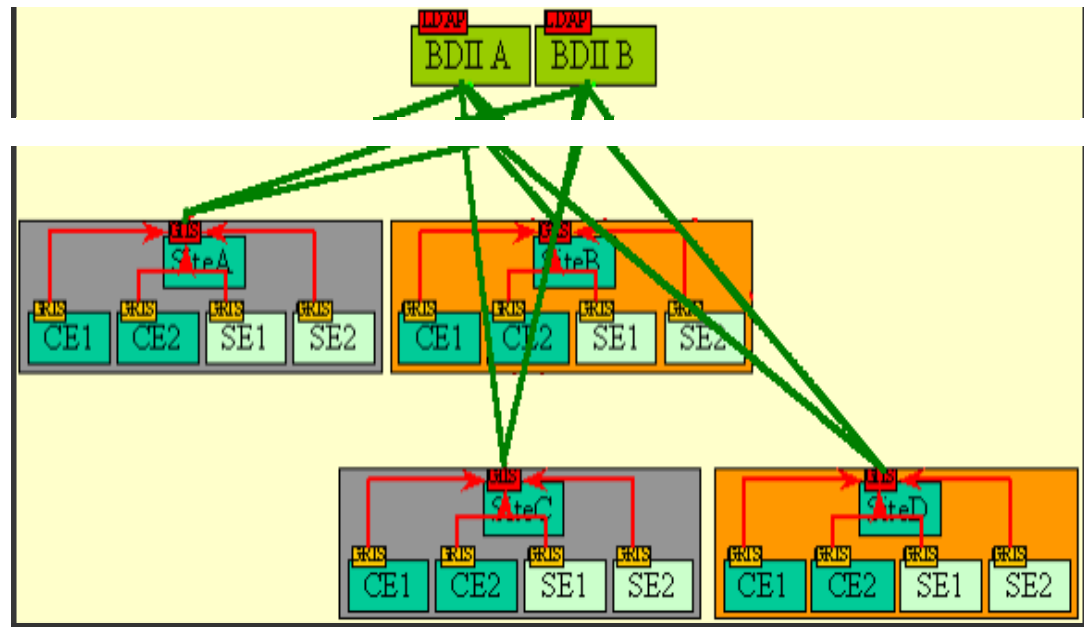

Monitoring and Discovery Service

- Querying the BDII a user or a service has all the available information about the status of the grid resources.
- Moreover in order to get more up-to-date information it is possible to querying directly the GISes or GRISes.

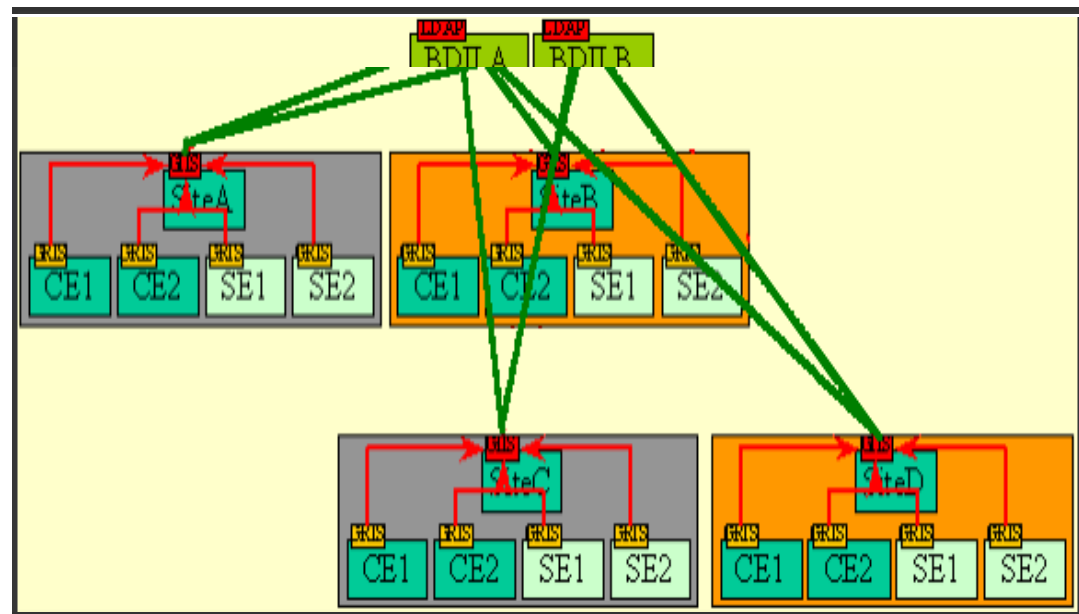

- The local GRISes runs on Computing Elements and Storage Elements and reports information on the characteristics and status of the services.
 - They give both static and dynamic information.
- In order to interrogate the GRIS on a specific Grid Element
 - the *hostname* (- **h**) of the Grid Element and the *TCP port* where the GRIS run must be specified (- **p**).
 - Port is always 2135.
 - - **X** option indicates that simple authentication should be used;
 - - **b** option is used to specify the initial entry from which starts the search in the LDAP tree.

E.g.: `$ ldapsearch -x -h <hostname>`
`-p 2135`
`-b "mds-vo-name=local, o=grid"`

or

`$ ldapsearch -x -H <LDAP_URI>`
`-b "mds-vo-name=local, o=grid"`

- The command used to interrogate the GRIS located on host `lxn1181.cern.ch` is:

```
$ ldapsearch -x  
-h lxn1181.cern.ch  
-p 2135  
-b "mds-vo-name=local, o=grid"
```

or:

```
$ ldapsearch -x  
-H ldap://lxn1181.cern.ch:2135  
-b "mds-vo-name=local, o=grid"
```

```

version: 2
#
# filter: (objectclass=*)
# requesting: ALL
#

# lxn1181.cern.ch/siteinfo, local, grid
dn: in=lxn1181.cern.ch/siteinfo,Mds-Vo-name=local,o=grid
objectClass: SiteInfo
objectClass: DataGridTop
objectClass: DynamicObject
siteName: CERN-LCG2
sysAdminContact: hep-project-grid-cern-testbed-managers@cern.ch
userSupportContact: hep-project-grid-cern-testbed-managers@cern.ch
siteSecurityContact: hep-project-grid-cern-testbed-managers@cern.ch
dataGridVersion: LCG-2_0_0beta
installationDate: 20040106120000Z

[...]
```

- At each site, a Site GIIIS collects information about all resources coming from all the GRISes.
- Usually a site GIIIS runs on a Computing Element.
- In order to interrogate the Site GIIIS
 - the *hostname* (- **h**) of the Grid Element and the *TCP port* where the GIIIS run must be specified (- **p**).
 - Port is always 2135.
 - - **X** option indicates that simple authentication should be used;
 - - **b** option is used to specify the initial entry from which starts the search in the LDAP tree.
 - A different base name must be used !

- The command used to interrogate the Site GIIIS located on lcgce02.ifa.e.es is:

```
$ ldapsearch -x
```

```
-H ldap://lcgce02.ifa.e.es:2170
```

```
-b "mds-vo-name=piclcg2,o=grid"
```

```

version: 2
#
# filter: (objectclass=*)
# requesting: ALL
#
# https://edt003.cnaf.infn.it:7772, infn-cnaf, grid
dn: GlueServiceURI=https://edt003.cnaf.infn.it:7772,Mds-Vo-
    name=infn-cnaf,o=gr
id
objectClass: GlueService
objectClass: GlueSchemaVersion
GlueServiceURI: https://edt003.cnaf.infn.it:7772
GlueServiceAccessPointURL: https://edt003.cnaf.infn.it:7772
GlueServiceType: ResourceBroker
GlueServicePrimaryOwnerName: LCG
GlueServicePrimaryOwnerContact: mailto:sitemanager@cnaf.infn.it
GlueServiceHostingOrganization: INFN-CNAF
GlueServiceMajorVersion: 1
GlueServiceMinorVersion: 00
[...]

```

- **In order to query directly the IS elements two high level tools are provided.**

lcg-infosites

lcg-info

- **These tools should be enough for most common user needs and will usually avoid the necessary of raw LDAP queries.**

- The **lcg-infosites** command can be used as an easy way to retrieve information on Grid resources for the most use cases.

USAGE: lcg-infosites --vo <vo name> options -v <verbose level> --is <BDII to query>

| | |
|----------------|---|
| ce | The information related to number of CPUs, running jobs, waiting jobs and names of the CEs are provided. All these data group all VOs together. With "-v 1" only the names of the queues will be printed while with "-v 2" The RAM Memory together with the operating system and its version and the processor included in each CE are printed. |
| se | The names of the SEs supported by the user's VO together with the kind of Storage System, the used and available space will be printed. With "-v 1" only the names of the SEs will be printed. |
| closeSE | The names of the CEs where the user's VO is allowed to run together with their corresponding closest SEs are provided. |
| lfc | Name of the lfc Catalog for the user's VO. |
| tag | The names of the tags relative to the software installed in site is printed together with the corresponding CE. |
| all | It groups together the information provided by ce, se, lrc and rmc. |
| is | If not specified the BDII defined in default by the variable LCG GFAL INFOSYS will be queried. However the user may want to query any other BDII without redefining this environment variable. This is possible specifying this argument followed by the name of the BDII which the user wants to query. All options admits this argument. |



Obtaining information about CE

Enrollment for E-science

```
$ lcg-infosites --vo gilda ce
```

```
*****
```

These are the related data for gilda: (in terms of queues and CPUs)

```
*****
```

| #CPU | Free | Total Jobs | Running | Waiting | Computing | Element |
|------|------|------------|---------|---------|-----------|---|
| 4 | 3 | 0 | 0 | 0 | | cn01.be.itu.edu.tr:2119/jobmanager-lcglsf-long |
| 4 | 3 | 0 | 0 | 0 | | cn01.be.itu.edu.tr:2119/jobmanager-lcglsf-short |
| 34 | 33 | 0 | 0 | 0 | | grid010.ct.infn.it:2119/jobmanager-lcgpbs-long |
| 16 | 16 | 0 | 0 | 0 | | grid011f.cnaf.infn.it:2119/jobmanager-lcgpbs-long |
| 1 | 1 | 0 | 0 | 0 | | grid006.cecalc.ula.ve:2119/jobmanager-lcgpbs-log |
| 2 | 1 | 1 | 0 | 1 | | gildace.oact.inaf.it:2119/jobmanager-lcgpbs-short |

[..]

```
$ lcg-infosites --vo gilda ce -v 2
```

| RAM | Memory | Operating System | System Version | Processor | CE Name |
|------|--------|------------------|----------------|-----------|---------------------------|
| 1024 | | SLC | 3 | P4 | ced-ce0.datagrid.cnr.it |
| 4096 | | SLC | 3 | Xeon | cn01.be.itu.edu.tr |
| 1024 | | SLC | 3 | PIII | cna02.cna.unicamp.br |
| 917 | | SLC | 3 | PIII | gilda-ce-01.pd.infn.it |
| 1024 | | SLC | 3 | Athlon | gildace.oact.inaf.it |
| 1024 | | SLC | 3 | Xeon | grid-ce.bio.dist.unige.it |

[..]



```
$ lcg-infosites --vo gilda se
```

```
*****
```

These are the related data for gilda: (in terms of SE)

```
*****
```

| Avail Space(Kb) | Used Space(Kb) | Type | SEs |
|-----------------|----------------|------|---------------------------|
| 143547680 | 2472756 | disk | cn02.be.itu.edu.tr |
| 168727984 | 118549624 | disk | grid009.ct.infn.it |
| 13908644 | 2819288 | disk | grid003.cecalc.ula.ve |
| 108741124 | 2442872 | disk | gildase.oact.inaf.it |
| 28211488 | 2948292 | disk | testbed005.cnaf.infn.it |
| 349001680 | 33028 | disk | gilda-se-01.pd.infn.it |
| 31724384 | 2819596 | disk | cna03.cna.unicamp.br |
| 387834656 | 629136 | disk | grid-se.bio.dist.unige.it |



```
$ lcg-infosites --vo gilda closeSE
```

Name of the CE: cn01.be.itu.edu.tr:2119/jobmanager-lcglsf-long

Name of the close SE: cn02.be.itu.edu.tr

Name of the CE: cn01.be.itu.edu.tr:2119/jobmanager-lcglsf-short

Name of the close SE: cn02.be.itu.edu.tr

Name of the CE: grid010.ct.infn.it:2119/jobmanager-lcgpbs-long

Name of the close SE: grid009.ct.infn.it

Name of the CE: grid011f.cnaf.infn.it:2119/jobmanager-lcgpbs-long

Name of the close SE: testbed005.cnaf.infn.it



```
$ lcg-infosites --vo gilda tag
```

```
*****
```

Information for gilda relative to their software tags included in each CE

```
*****
```

```
Name of the TAG: VO-gilda-GEANT
Name of the TAG: VO-gilda-GKS05
  Name of the CE:cn01.be.itu.edu.tr
```

```
Name of the TAG: VO-gilda-slc3_ia32_gcc323
Name of the TAG: VO-gilda-CMKIN_5_1_1
Name of the TAG: VO-gilda-GEANT
Name of the TAG: VO-gilda-GKS05
  Name of the CE:grid010.ct.infn.it
```

```
[..]
```



- This command can be used to list either CEs or the SEs that satisfy a given set of conditions, and to print the values of a given set of attributes.
- The information is taken from the BDII specified by the **LCG_GFAL_INFOSYS** environment variable.

- The query syntax is like this:

attr1 op1 valueN, ...
attrN opN valueN

After the upgrading of the new GLUE SCHEMA it's not possible use the operators '>' and '<'

where *attrN* is an attribute name

op is =, >= or <=, and the cuts are ANDed.

The cuts are comma-separated and spaces are not allowed.

USAGE

lcg-info --list-ce [--bdii bdii] [--vo vo] [--sed] [--query query] [--attrs list]

lcg-info --list-se [--bdii bdii] [--vo vo] [--sed] [--query query] [--attrs list]

lcg-info --list-attrs

lcg-info --help

| | |
|---------------------|--|
| --list-attrs | Prints a list of the attributes that can be queried. |
| --list-ce | Lists the CEs which satisfy a query, or all the CEs if no query is given. |
| --list-se | Lists the SEs which satisfy a query, or all the SEs if no query is given. |
| --query | Restricts the output to the CEs (SEs) which satisfy the given query. |
| --bdii | Allows to specify a BDII in the form <code>:.:</code> . If not given, the value of the environmental variable <code>LCG_GFAL_INFOSYS</code> is used. If that is not defined, the command returns an error. |
| --sed | Print the output in a "sed-friendly" format. |
| --attrs | Specifies the attributes whose values should be printed. |
| --vo | Restricts the output to CEs or SEs where the given VO is authorized. Mandatory when VO-dependent attributes are queried upon. |



Get the list of supported attributes

```
$ lcg-info --list-attrs
```

Attribute name Glue object class

Glue attribute name

| | | |
|----------------|----------------------|---|
| MaxTime | GlueCE | GlueCEPolicyMaxWallClockTime |
| CEStatus | GlueCE | GlueCEStateStatus |
| TotalJobs | GlueCE | GlueCEStateTotalJobs |
| CEVOs | GlueCE | GlueCEAccessControlBaseRule |
| TotalCPUs | GlueCE | GlueCEInfoTotalCPUs |
| FreeCPUs | GlueCE | GlueCEStateFreeCPUs |
| CE | GlueCE | GlueCEUniqueID |
| WaitingJobs | GlueCE | GlueCEStateWaitingJobs |
| RunningJobs | GlueCE | GlueCEStateRunningJobs |
| CloseCE | GlueCESEBindGroup | GlueCESEBindGroupCEUniqueID |
| CloseSE | GlueCESEBindGroup | GlueCESEBindGroupSEUniqueID |
| SEVOs | GlueSA | GlueSAAccessControlBaseRule |
| UsedSpace | GlueSA | GlueSAStateUsedSpace |
| AvailableSpace | GlueSA | GlueSAStateAvailableSpace |
| Type | GlueSE | GlueSEType |
| SE | GlueSE | GlueSEUniqueID |
| Protocol | GlueSEAccessProtocol | GlueSEAccessProtocolType |
| ArchType | GlueSL | GlueSLArchitectureType |
| Processor | GlueSubCluster | GlueHostProcessorModel |
| OS | GlueSubCluster | GlueHostOperatingSystemName |
| Cluster | GlueSubCluster | GlueSubClusterUniqueID |
| Tag | GlueSubCluster | GlueHostApplicationSoftwareRunTimeEnvironment |
| Memory | GlueSubCluster | GlueHostMainMemoryRAMSize |



List all the CE(s) in the BDI1 satisfying given conditions

```
$ lcg-info --list-ce --query 'TotalCPUs=10,OS=SL*' --attrs  
  'RunningJobs,FreeCPUs'
```

- CE: dgt01.ui.savba.sk:2119/jobmanager-lcgpbs-long
 - RunningJobs 0
 - FreeCPUs 10

 - CE: dgt01.ui.savba.sk:2119/jobmanager-lcgpbs-short
 - RunningJobs 0
 - FreeCPUs 10

 - CE: dgt01.ui.savba.sk:2119/jobmanager-lcgpbs-infinite
 - RunningJobs 1
 - FreeCPUs 10

 - CE: gilda-ce-01.pd.infn.it:2119/jobmanager-lcgpbs-long
 - RunningJobs 0
 - FreeCPUs 10

 - CE: grid011f.cnaf.infn.it:2119/jobmanager-lcgpbs-gilda
 - RunningJobs 0
 - FreeCPUs 10
- [..]





Print all the tags published by a specific query

```
$ lcg-info --list-ce --query 'CE=*grid-ce.bio.dist.unige.it*' --attrs 'Tag'
```

PBS
INFN
LCG-2
LCG-2_1_0
LCG-2_1_1
LCG-2_2_0
LCG-2_3_0
LCG-2_3_1
LCG-2_4_0
R-GMA
AFS
CMS-1.1.0
ATLAS-6.0.4
GATE-1.0.0-3
LHCb-1.1.1
IDL-5.4
CMSIM-125
ALICE-4.01.00
ALIEN-1.32.14
POVRAY-3.5
DEMTTOOLS-1.0

CMKIN-VALID
CMKIN-1.1.0
CMSIM-VALID
CSOUND-4.13
MPICH
VIRGO-1.0
CMS-OSCAR-2.4.5
LHCb_dbase_common-v3r1
GEANT4-6
VLC-0.7.2
EGEODE-1.0
RASTER3D
SCILAB-2.6
G95-3.5.0
MAGIC-6.19
CODESA3D-1.0
VO-gilda-slc3_ia32_gcc323
VO-gilda-CMKIN_5_1_1
VO-gilda-GEANT
VO-gilda-GKS05



List the CEs with a particular SW

```
$ lcg-info --vo gilda --list-ce --query  
  'Tag=*MPICH*' --attrs 'CE'
```

- CE: cn01.be.itu.edu.tr:2119/jobmanager-lcglsf-long
- CE cn01.be.itu.edu.tr:2119/jobmanager-lcglsf-long

- CE: cn01.be.itu.edu.tr:2119/jobmanager-lcglsf-short
- CE cn01.be.itu.edu.tr:2119/jobmanager-lcglsf-short

- CE: grid010.ct.infn.it:2119/jobmanager-lcgpbs-long
- CE grid010.ct.infn.it:2119/jobmanager-lcgpbs-long

- CE: grid011f.cnaf.infn.it:2119/jobmanager-lcgpbs-long
- CE grid011f.cnaf.infn.it:2119/jobmanager-lcgpbs-long

- CE: ced-ce0.datagrid.cnr.it:2119/jobmanager-lcgpbs-long
- CE ced-ce0.datagrid.cnr.it:2119/jobmanager-lcgpbs-long

[..]





LCG-2 User Guide Manual Series

<https://edms.cern.ch/file/454439/LCG-2-UserGuide.html>

R-GMA

- **Relational Grid Monitoring Architecture (R-GMA)**
 - Developed as part of the EuropeanDataGrid Project (EDG)
 - Now as part of the EGEE project.
 - Based on the Grid Monitoring Architecture (GMA) from the Global Grid Forum (GGF).
- **Uses a relational data model.**
 - Data are viewed as tables.
 - Data structure defined by the columns.
 - Each entry is a row (tuple).
 - Queried using Structured Query Language (SQL).

- The Producer stores its location (URL) in the Registry.
- The Consumer looks up producer URLs in the Registry.
- The Consumer contacts the Producer to get all the data or to listen for new data.

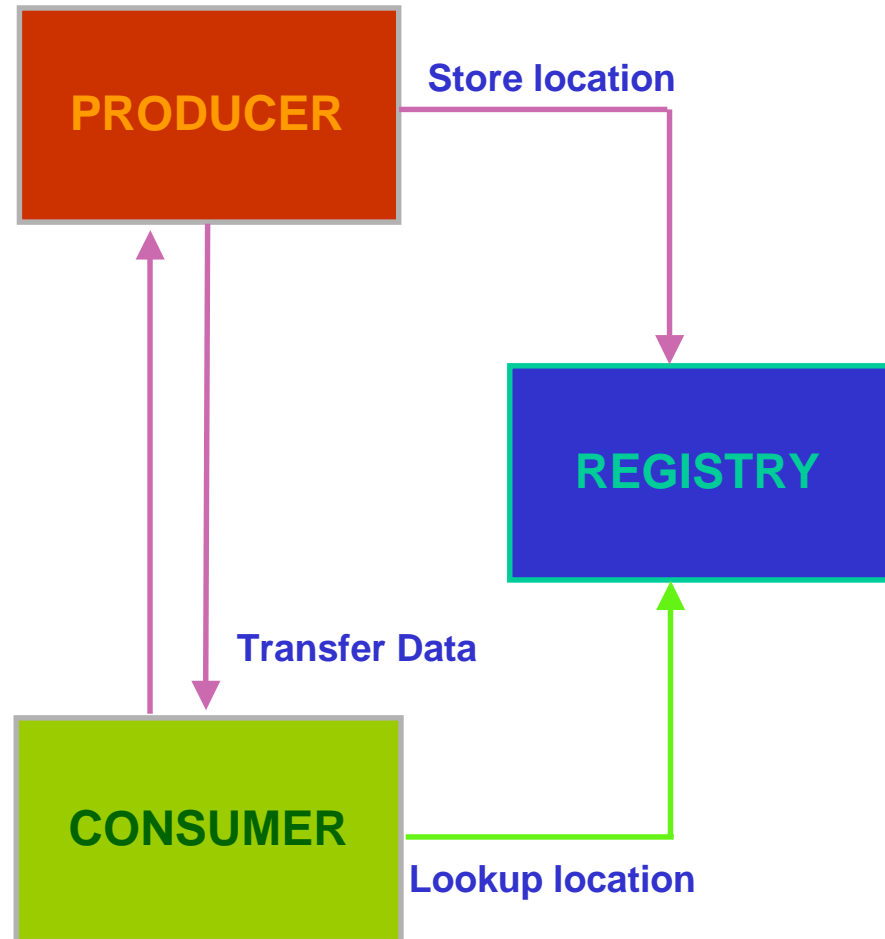

- **Three types of Producer Services**
 - **Primary Producer:** Produces and stores tuples in its tuples store
 - **Secondary Producer:** Collects tuples by querying Primary Producers and stores them locally
 - **On Demand Producer:** Produce tuples on demand. Does not store produced tuple in any case
- **One type of Consumer Service**
 - **Consumer:** Queries the virtual database to get tuples according to SQL query syntax
- **Virtual Database with three type of Services**
 - **Registry:** Contains information to match consumer queries with right producers
 - **Schema:** Stores schemas of tables in terms of columns definitions
 - **Mediator:** Matches queries made by consumers with right producers

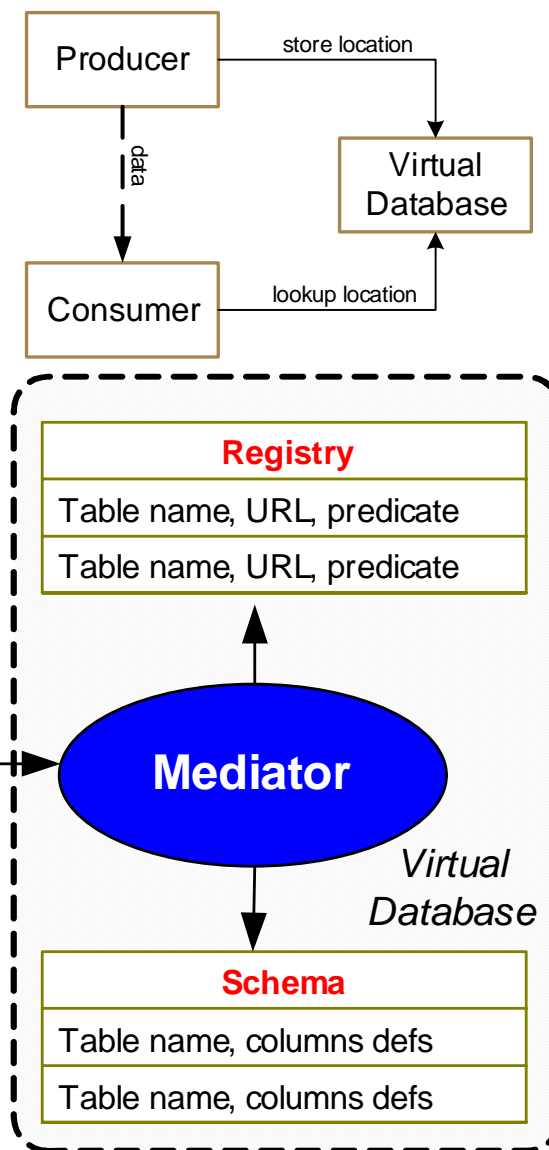

- **The Producer**
 - Calls a **declareTable** primitive to declare its intention to publish tuples in a given table
 - Hands a predicate string to the mediator in the same primitive
- **The Mediator**
 - Receives the request
 - Stores this data into the registry
- **The Predicate**
 - A string describing which tuples will be published by this producers
 - It is a collection of *AND* clause in which the value of some columns are defined as constants

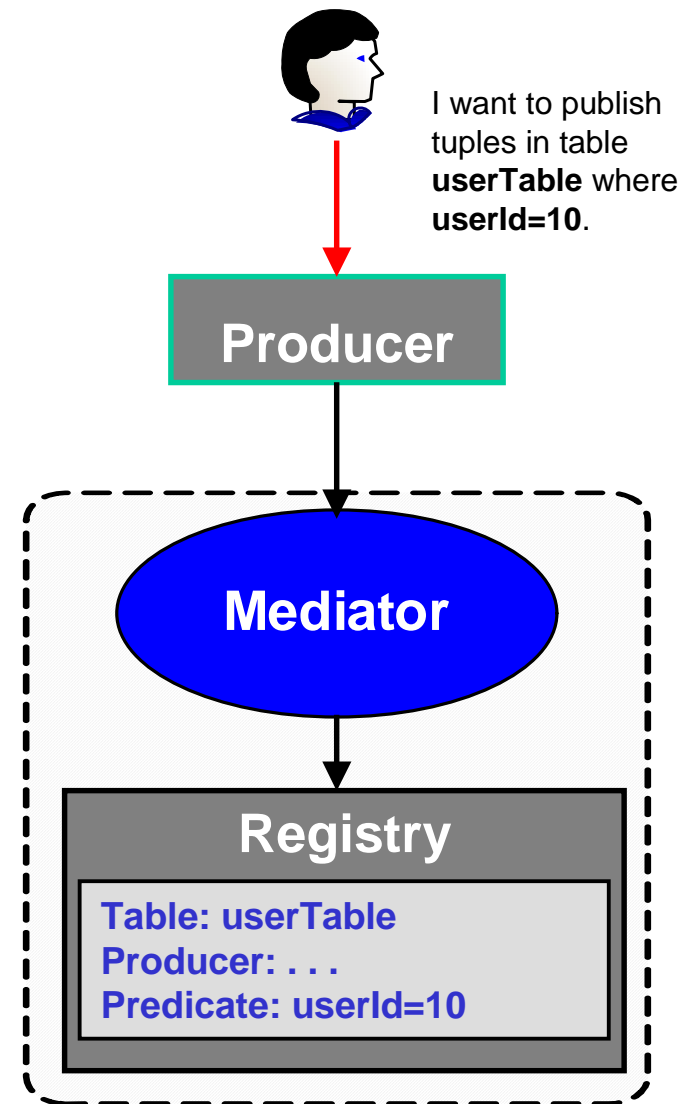

The user stores a new tuple in the virtual database



insert into
(tuple description)

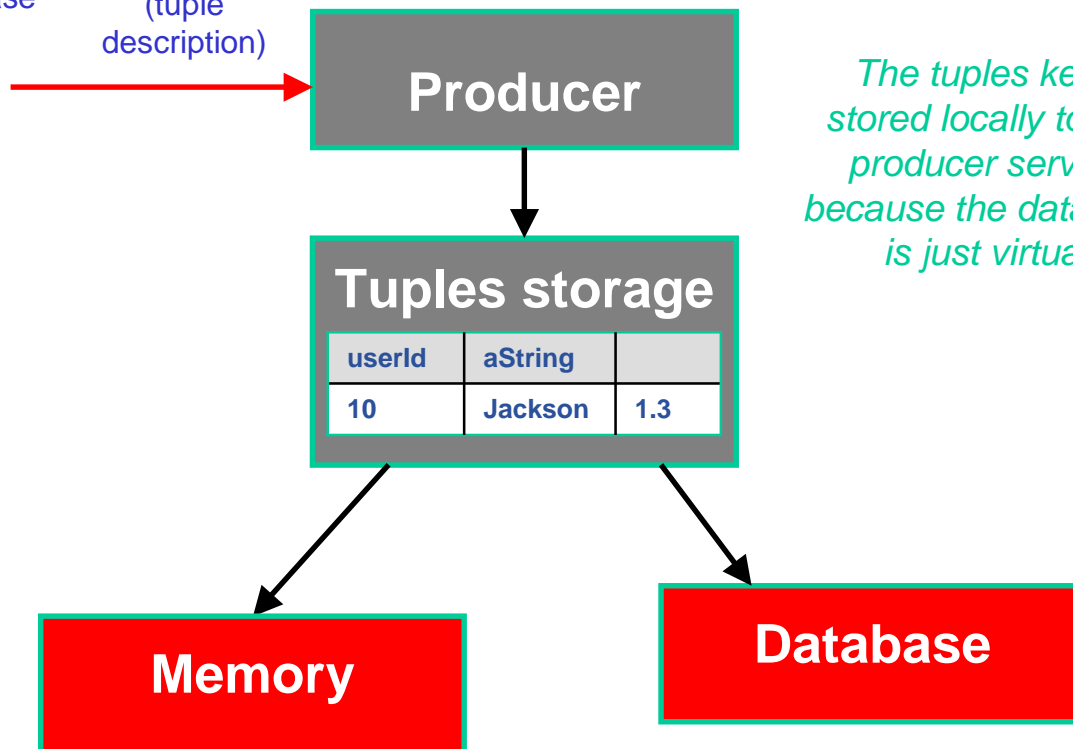

The tuples keep stored locally to the producer service because the database is just virtual

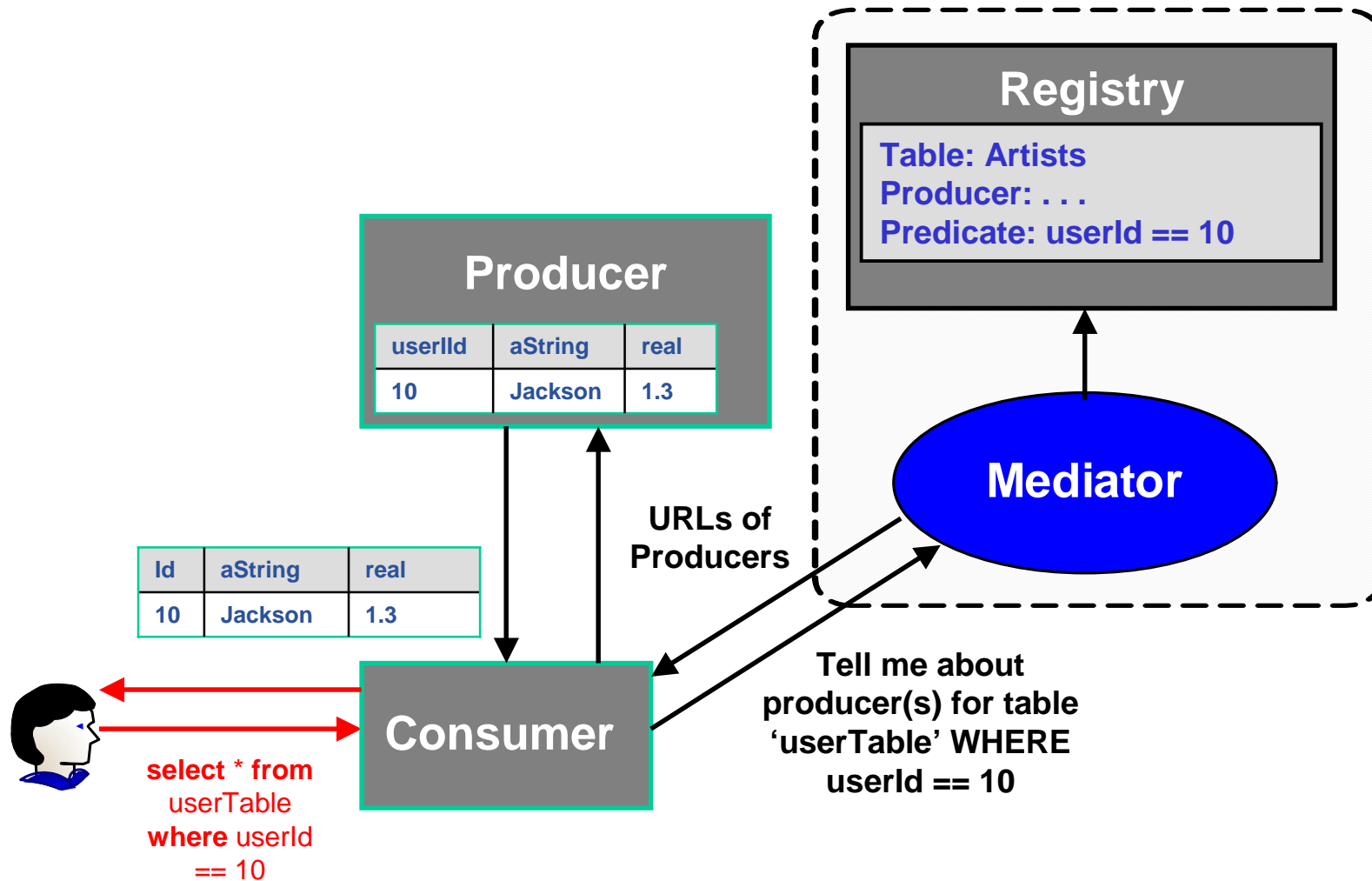

- **Primary Producer**

- Creates and stores tuples in its local tuples storage

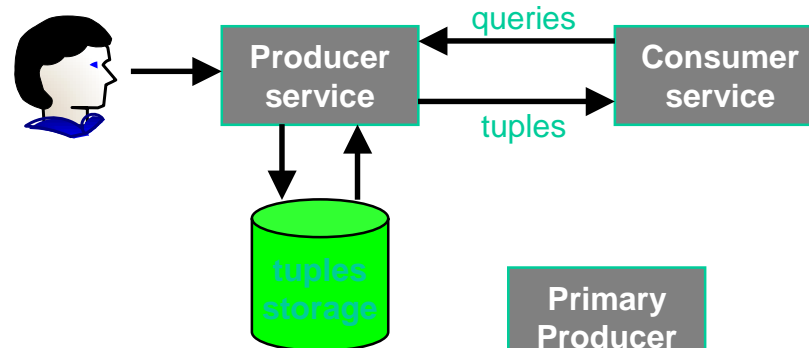

- **Secondary Producer**

- Just stores tuples in its tuples storage
- Collects tuples as it was a Consumer to Primary Producers

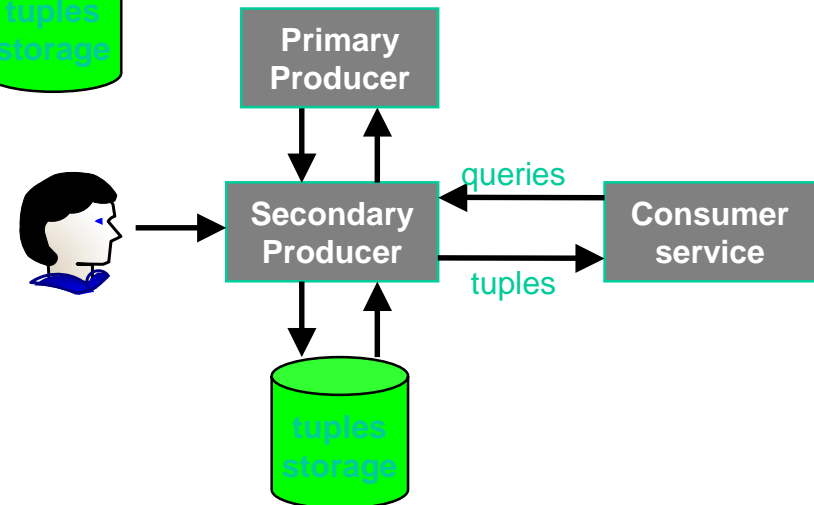

- **On Demand Producer**

- Generates tuples just in time in response to Consumer queries
- A proper code provides for the production of tuples just in time

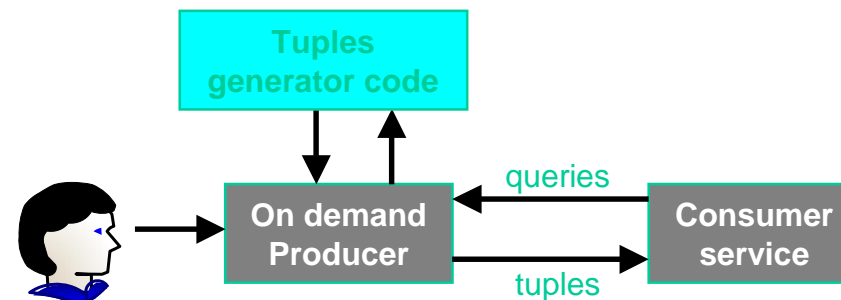

- **Continuous**
 - To create a stream channel from producers to consumers that works in real time
 - (more in next slide)
- **Latest**
 - To get the latest tuple published by a Producer
 - The Producer specifies a **Latest Retention Period (LRP)** as deadline for the produced tuple
 - Tuples are stored in a Latest Storage
- **History**
 - To get all tuples less old than a **History Retention Period (HRP)**
 - Tuples are stored in a History Storage
- **Static**
 - Supported only by On-Demand Producers
 - To make not R-GMA data storage accessible through R-GMA infrastructure

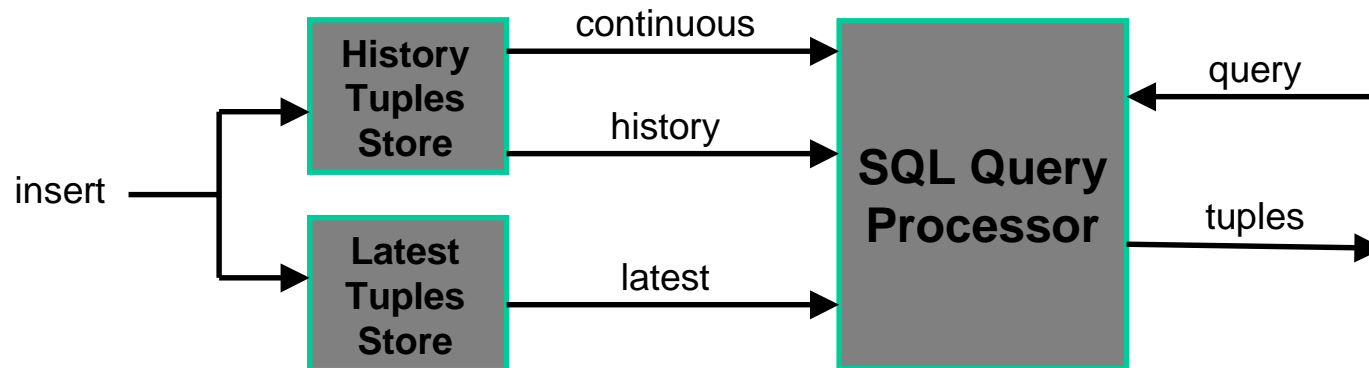

- **Way of working**
 - One Consumer asks the Registry for Producers who put tuples in the virtual database that satisfy the Consumer query
 - The Registry responds with a list of suitable Producers
 - The Consumer subscribes with these Producers to get all new tuples that satisfy the query
 - Each time anyone of the suitable Producers inserts a new tuple that satisfies the query, that tuple is streamed to the Consumer
 - One way streams of tuples are now created between the suitable Producers and the Consumers
 - The registry keeps track of the Consumer to notify it in the event of the addition of a new suitable Producer
- **Duration of the Stream**
 - A time parameter defines how long the channel has to work
 - Periodically the Registry checks for the Consumer to be alive. If not, the Registry deregisters the Consumers from its list of Continuous Consumers

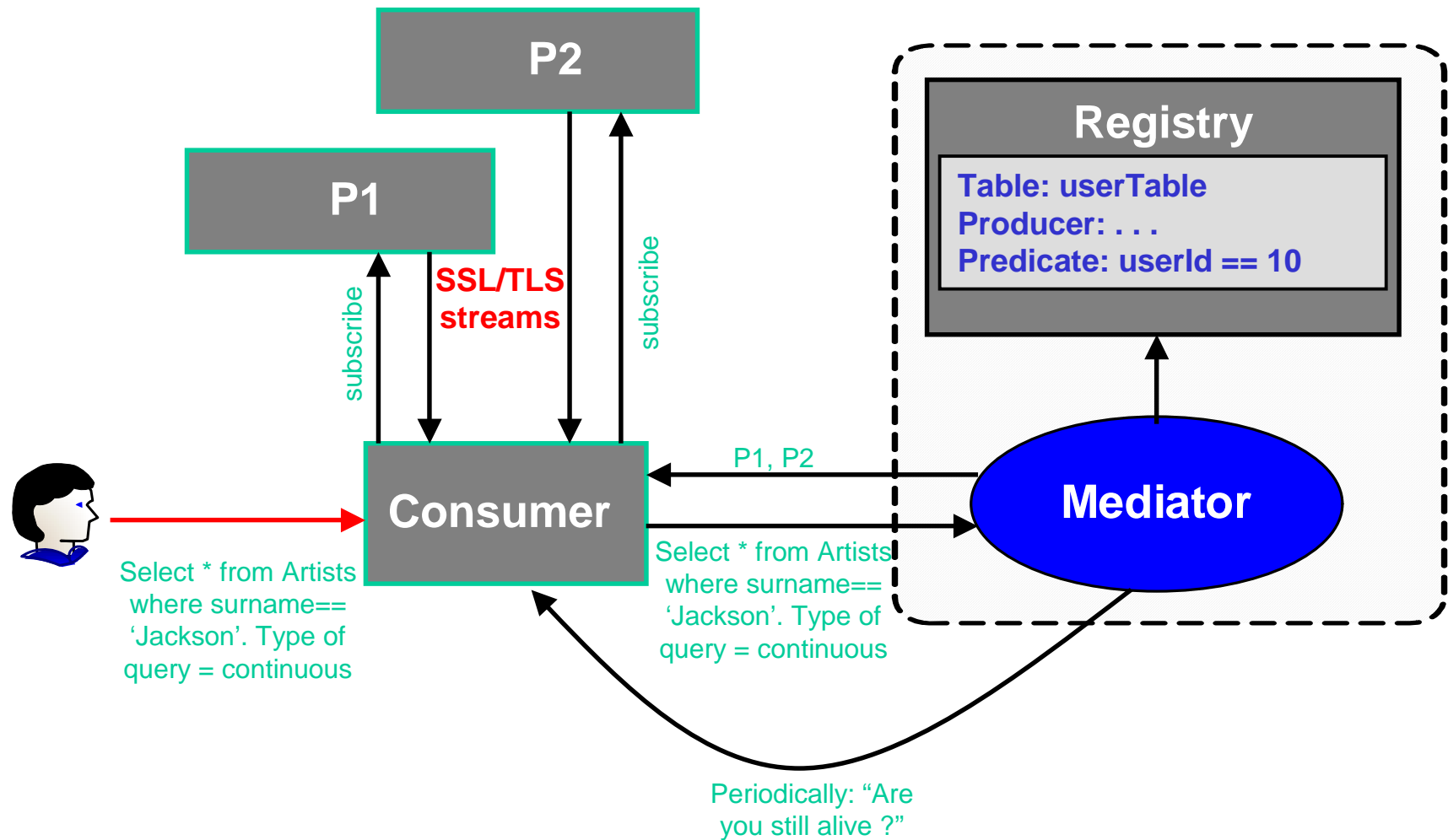

- **APIs exist in Java, C, C++, Python.**
 - For clients (servlets contacted behind the scenes)
- **They include methods for...**
 - Creating consumers
 - Creating primary and secondary producers
 - Setting type of queries, type of produces, retention periods, time outs...
 - Retrieving tuples, inserting data
 - ...
- **You can create your own Producer or Consumer.**

- **The easiest way to try out R-GMA.**
 - It is installed on the machine running the Registry and Schema:
<https://rgmasrv.ct.infn.it:8443/R-GMA>
- **Using the Browser you can do the following.**
 - Browse the tables in the schema.
 - Look at the table definitions.
 - See all the available producers for a table.
 - Query a table.
 - Query only selected producers.

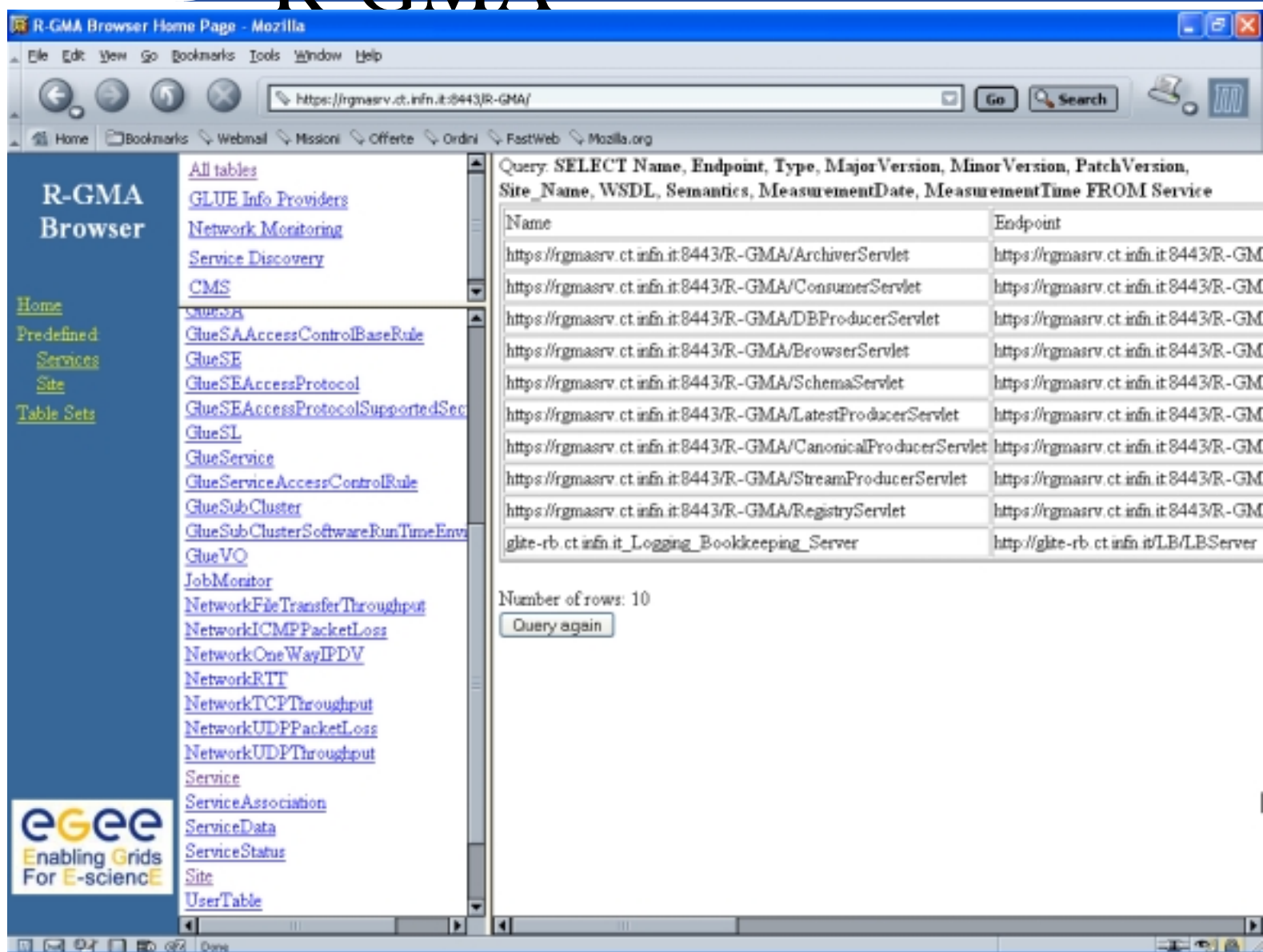

R-GMA Browser Home Page - Mozilla

File Edit View Go Bookmarks Tools Window Help

https://rgmasrv.ct.infn.it:8443/R-GMA/

Home Bookmarks Webmail Missioni Offerte Ordini FastWeb Mozilla.org

R-GMA Browser

Home
Predefined Services Site
Table Sets

All tables
[GLUE Info Providers](#)
[Network Monitoring](#)
[Service Discovery](#)
[CMS](#)

[Sources](#)
[GlueSAAccessControlBaseRule](#)
[GlueSE](#)
[GlueSEAccessProtocol](#)
[GlueSEAccessProtocolSupportedSec](#)
[GlueSL](#)
[GlueService](#)
[GlueServiceAccessControlRule](#)
[GlueSubCluster](#)
[GlueSubClusterSoftwareRunTimeEnv](#)
[GlueVO](#)
[JobMonitor](#)
[NetworkFileTransferThroughput](#)
[NetworkICMPPacketLoss](#)
[NetworkOneWayIPDV](#)
[NetworkRTT](#)
[NetworkTCPThroughput](#)
[NetworkUDPPacketLoss](#)
[NetworkUDPTThroughput](#)
[Service](#)
[ServiceAssociation](#)
[ServiceData](#)
[ServiceStatus](#)
[Site](#)
[UserTable](#)

Query: SELECT Name, Endpoint, Type, MajorVersion, MinorVersion, PatchVersion, Site_Name, WSDL, Semantics, MeasurementDate, MeasurementTime FROM Service

| Name | Endpoint |
|--|--|
| https://rgmasrv.ct.infn.it:8443/R-GMA/ArchiverServlet | https://rgmasrv.ct.infn.it:8443/R-GM |
| https://rgmasrv.ct.infn.it:8443/R-GMA/ConsumerServlet | https://rgmasrv.ct.infn.it:8443/R-GM |
| https://rgmasrv.ct.infn.it:8443/R-GMA/DBProducerServlet | https://rgmasrv.ct.infn.it:8443/R-GM |
| https://rgmasrv.ct.infn.it:8443/R-GMA/BrowserServlet | https://rgmasrv.ct.infn.it:8443/R-GM |
| https://rgmasrv.ct.infn.it:8443/R-GMA/SchemaServlet | https://rgmasrv.ct.infn.it:8443/R-GM |
| https://rgmasrv.ct.infn.it:8443/R-GMA/LatestProducerServlet | https://rgmasrv.ct.infn.it:8443/R-GM |
| https://rgmasrv.ct.infn.it:8443/R-GMA/CanonicalProducerServlet | https://rgmasrv.ct.infn.it:8443/R-GM |
| https://rgmasrv.ct.infn.it:8443/R-GMA/StreamProducerServlet | https://rgmasrv.ct.infn.it:8443/R-GM |
| https://rgmasrv.ct.infn.it:8443/R-GMA/RegistryServlet | https://rgmasrv.ct.infn.it:8443/R-GM |
| glite-rb.ct.infn.it_Logging_Bookkeeping_Server | http://glite-rb.ct.infn.it/LB/LBServer |

Number of rows: 10

- **Network Security**
 - All network communications are over SSL encrypted channels
 - One weak point: The URI to which On Demand Producers forward their messages because we don't any guarantees
- **Authentication**
 - X509 certificates
 - Mutual authentication between peers
- **Authorization**
 - Grid credential extracted by the certificate
 - Adoption of VOMS
- **Ownership**
 - One R-GMA infrastructure for each VO
 - One owner for each VDB who decides who read, write etc...

GLUE Schema

- **Grid Laboratory Uniform Environment (GLUE) Schema**
 - It is a data model to describe in a meaningful way information on grid resources (static and dynamic info)
 - As result of a collaboration between the EU-DataTAG and iVDGL projects
 - Then, EGEE, NorduGrid, LCG and Grid3/OSG have contributed to the definition of the schema
- **XML Schema**
 - Now, GLUE Schema is being mapped to an XML representation
 - <http://infforge.cnaf.infn.it/glueinfomodel/Spec/V12>

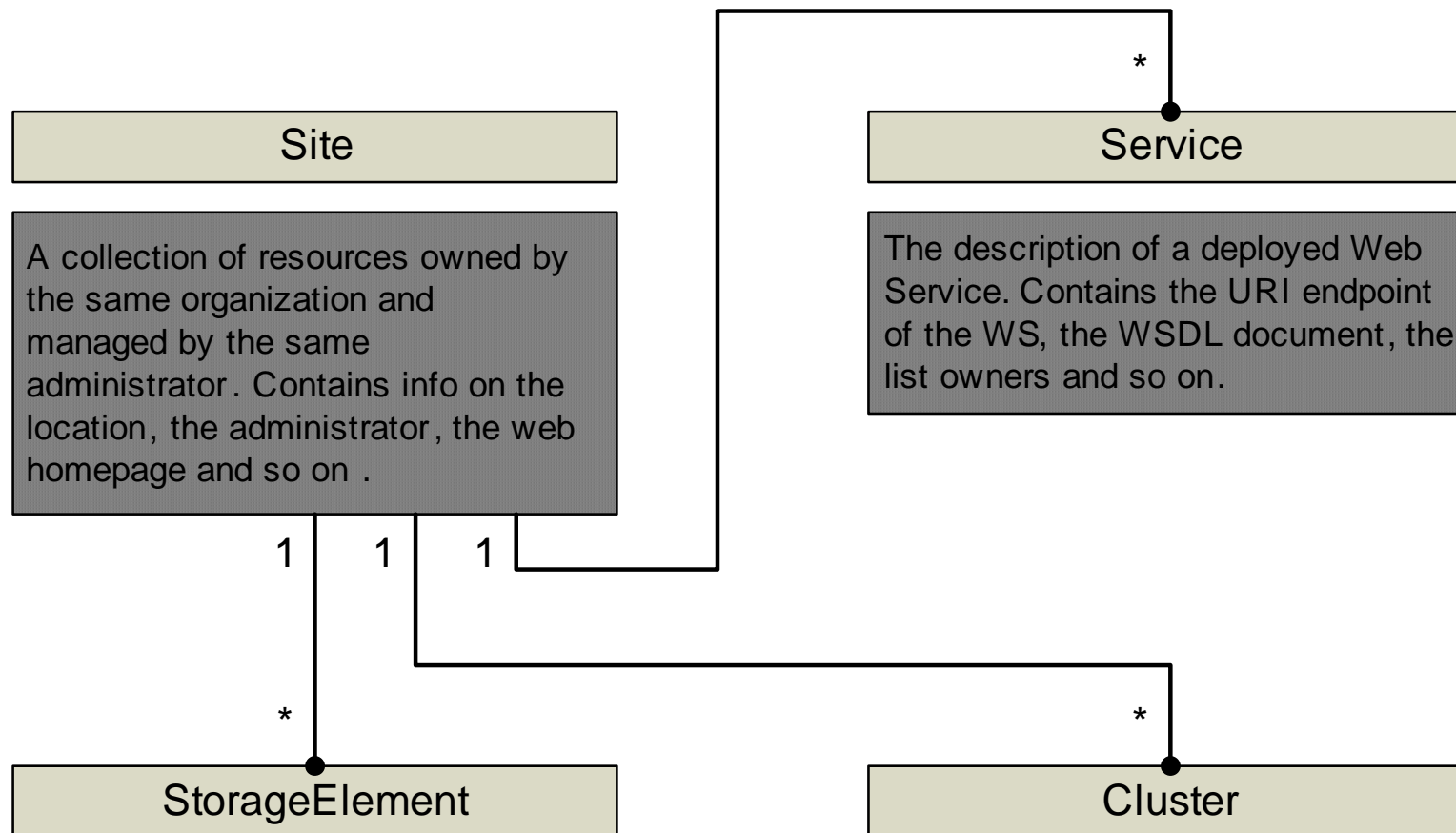

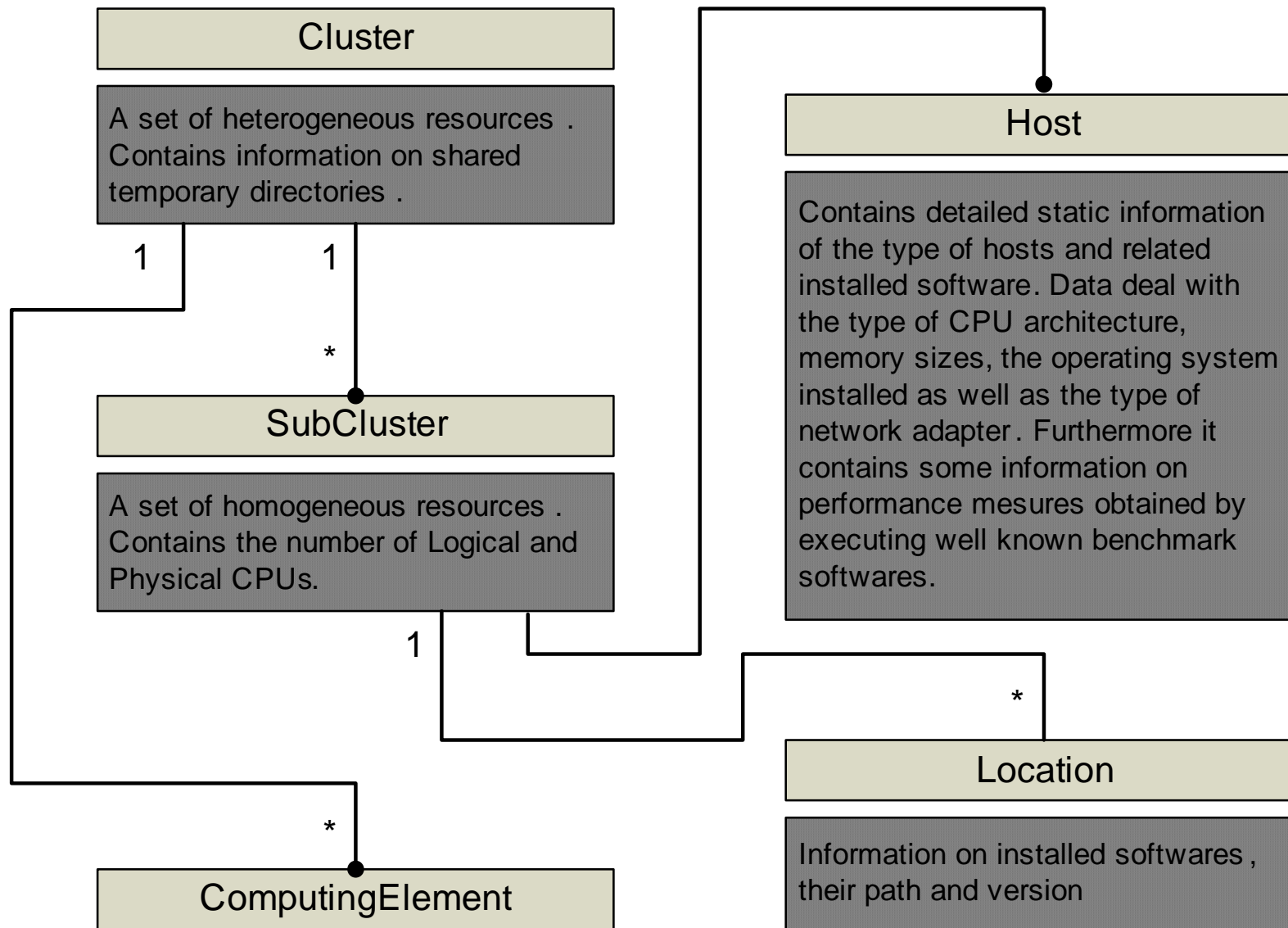

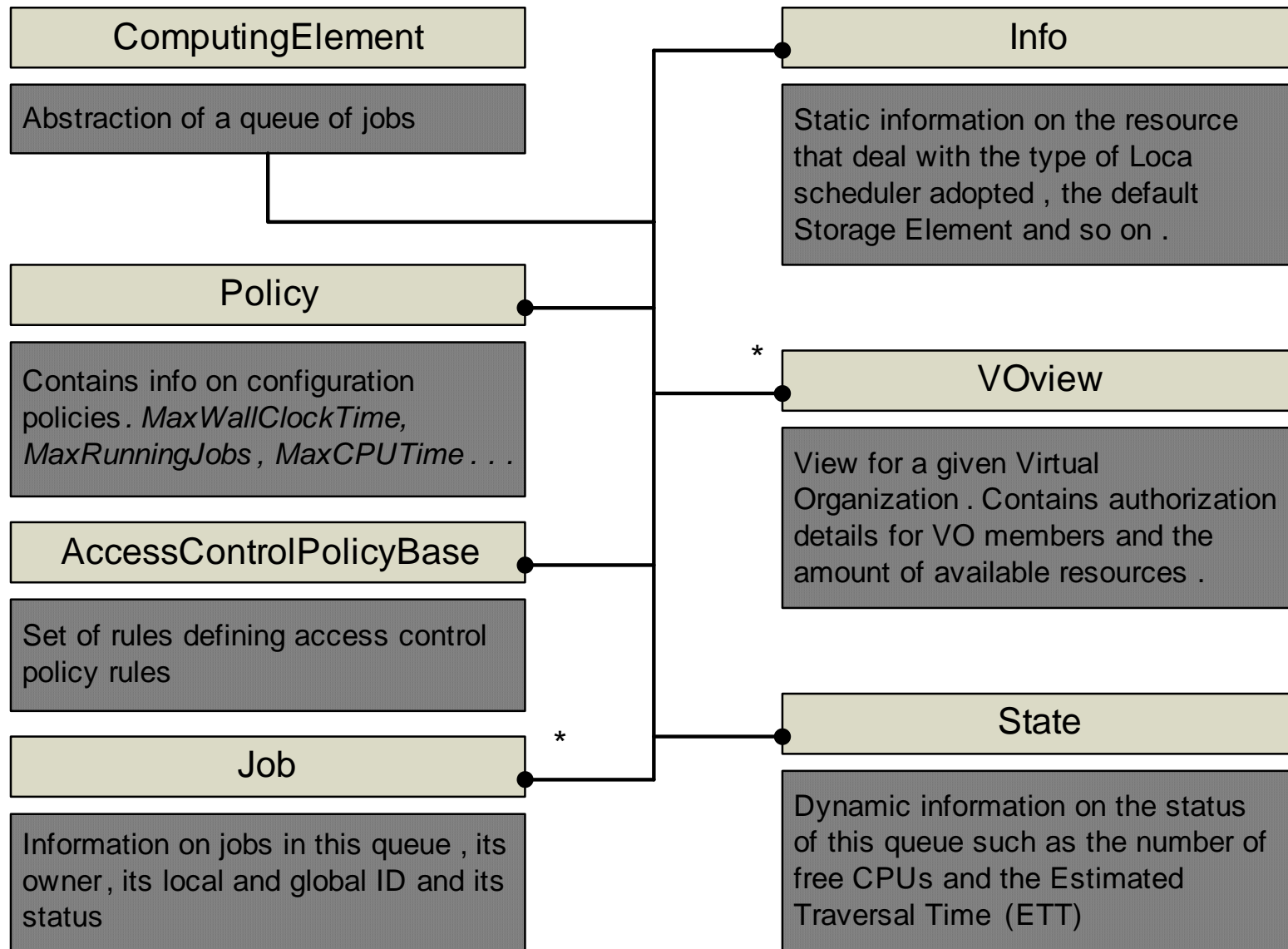

- **R-GMA overview page.**
 - <http://www.r-gma.org/>
- **R-GMA in EGEE**
 - <http://hepunx.rl.ac.uk/egee/jra1-uk/>
- **R-GMA Documenation**
 - <http://hepunx.rl.ac.uk/egee/jra1-uk/glite-r1/>
- **GLUE Schema**
 - <http://infforge.cnaf.infn.it/glueinfomodel/>

Questions...

